



ORBI-G4

The Orbi-G4 is similar to the G3 model, but consists of 2 nozzle heads. The G4 provides a thorough 360-degree indexing spray pattern that repeats every 45 revolutions.

- Ideal for cleaning of totes, IBCs or processing tanks in most industries.
- High-impact cleaning.
- Self-cleaning flow-through design.
- Simple design means ease of field service.

SPECS

- Minimum Opening: 3.75'
- PSI / Bar: 50-300 / 3.5-20.7
- GPM / LPM: 8-35 / 30-125
- Cleaning Radius: 15'
- Pipe Connections: 3/4" Female NPT
- Maximum Operating Temperature: 250°
- Weight: 3 lbs.



Orbi-G4 Performance Curves

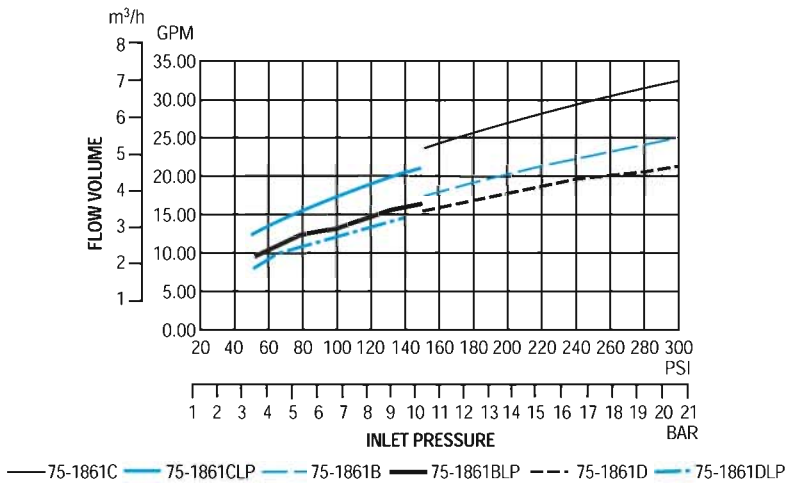

Parts List

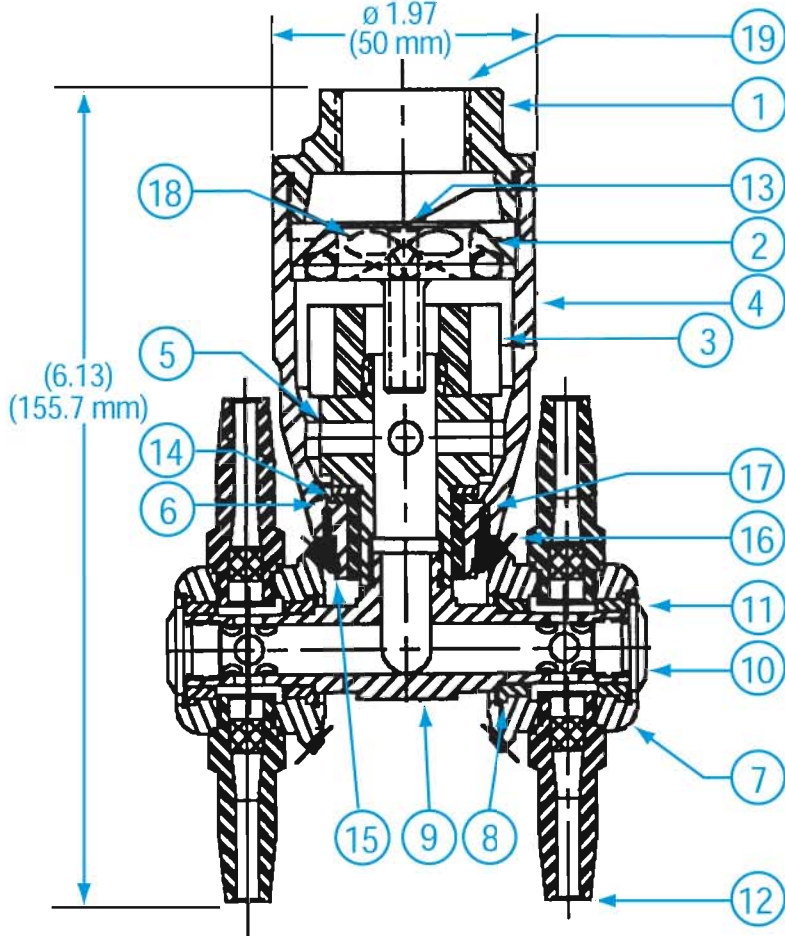

Item No.	Part or Identifying No.	Description
1	75-1403	Cap, Inlet
2	75-1857	Motor, Water, 4 hole
3	75-1801SS	Rotor, 6 Tooth
4	75-1853	Body, Main
5	75-1854	Shaft, Vertical
6	75-1862	Bushing, Shaft
7	75-1851	Body, Nozzle, Geared
8	75-1846	Bushing
9	75-1860	Shaft, Elbow
10	75-1844	Cap, Shaft
11	75-1847	Ring, Retaining
12	75-1849CA	Nozzle Assembly, $\varnothing.172$
13		Plug, Bypass, size as required
14	75-1863G	Washer
15	75-1855	Ring, Retaining
16	75-1852	Gear, Bevel
17	75-1856	Pin, Roll, $\varnothing.062$
18	75-1455-D	Plug, Bypass, $\varnothing.156$
19		Protective Cap
20	625-03561	Never Seez
21	75-1861-SPK	Kit, Parts, Spare
21-1	75-1856	Pin, Roll, $\varnothing.062$
21-2	75-1863G	Washer
21-3	75-1847	Ring, Retaining
21-4	75-1846	Bushing
21-5	75-1862	Bushing, Shaft
21-6	7-33-1	Plug, Bypass, Solid

