

CLOUD-SELLERS MODEL 360 EXPLODED VIEW & PARTS LIST

Use Recommendations:

Refer to the Exploded Views accompanying illustration numbers. Locate matching illustration number in the left hand column of the parts lists. Use the line information given beneath the appropriate column heading for all ordering and reference purposes.

Portable vs. Clean-In-Place (C.I.P.) Machines

This is an exploded view of a portable tank cleaning machine. If you are ordering cast parts for a C.I.P. machine, pay special attention to the (*) adjacent to the illustration No. in the castings section of the parts list. The (*) indicates which parts are modified at the factory to allow for special self-rinsing C.I.P. capabilities. Refer to the C.I.P. component chart on the back page for specific part numbers for ordering or reference purposes.

Lubricated vs. Flow-thru Gearbox

The lubricated type of gearbox is sealed from the cleaning solution, and uses a food-grade oil for lubrication of the geartrain. The flow-thru type of gearbox uses the cleaning solution for lubrication of the geartrain, and can be identified by the 5/32" drain hole in the gearbox cover on the bottom of the machine. Many components are common to both types of gearboxes, while some are specific to the lubricated or flow-thru type machines. Be sure to choose the appropriated column heading when selecting a part number.

O-ring Selection

The type of o-ring recommended for your application depends primarily upon the composition of the cleaning solution used. The chart below gives a general compatibility rating for the three types of stock o-rings available for the 360 tank cleaning machine. For more specific data, or special o-ring compound selection, contact your representative.



**FOR ALL SPARE
PARTS ORDERING
& ASSEMBLY
PURPOSES**

	EPR	Viton
Water	A	B
Mild Caustic	A	B
Heavy Caustic	A	B
Mild Acid Solution	A	B
Chlorinated Solvents	C	A
Petroleum Oils	C	A

A = Best B = Satisfactory C = Not Recommended

Gearbox Bearing Selection

As a general rule, oil lubricated gearboxes will use oil-impregnated bronze bearings, while flow-thru gearboxes will use oil-impregnated bronze or bearings or a PTFE type bearing material. Ask your representative for more specific information regarding bearing material selection for your cleaning application

CLOUD-SELLERS 360 EXPLODED VIEW & PARTS LIST

MACHINE CONFIGURATION NUMBER

MACHINE COMPONENT DESCRIPTION

DESCRIPTION	OPTION	OPTION	OPTION
Cast Type	Stainless		
Inlet Stem Type	Quick	Male OT	
Stator Type	STD	LP	
Rotor Type	STD	LP	
No. of Nozzles	Dual	Triple	
Nozzle Size	3/8" (9.5 MM)	5/16" (7.9 MM)	
Drive Type	Clutch	Pin	
Clean-In-Place	No	Yes	
External Rinse	No	Yes	
Gear Ratio	655:1	273:1	
Gearbox Type	Lube	Flow-Thru	
O-Ring Type	Viton	EPR	
Bearing Type	Oilite	PTFE	

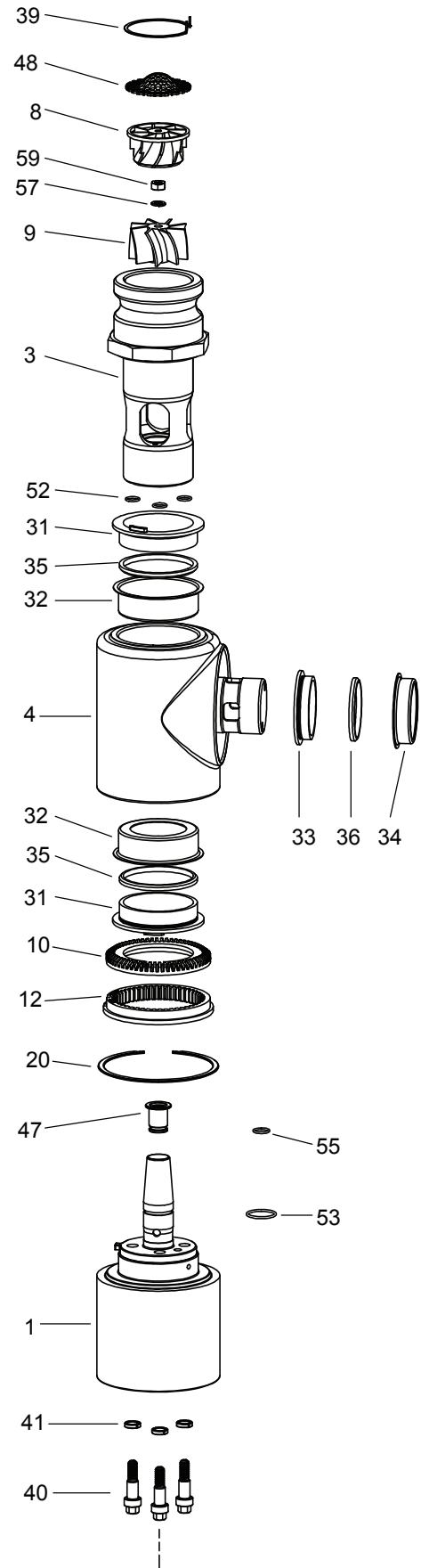
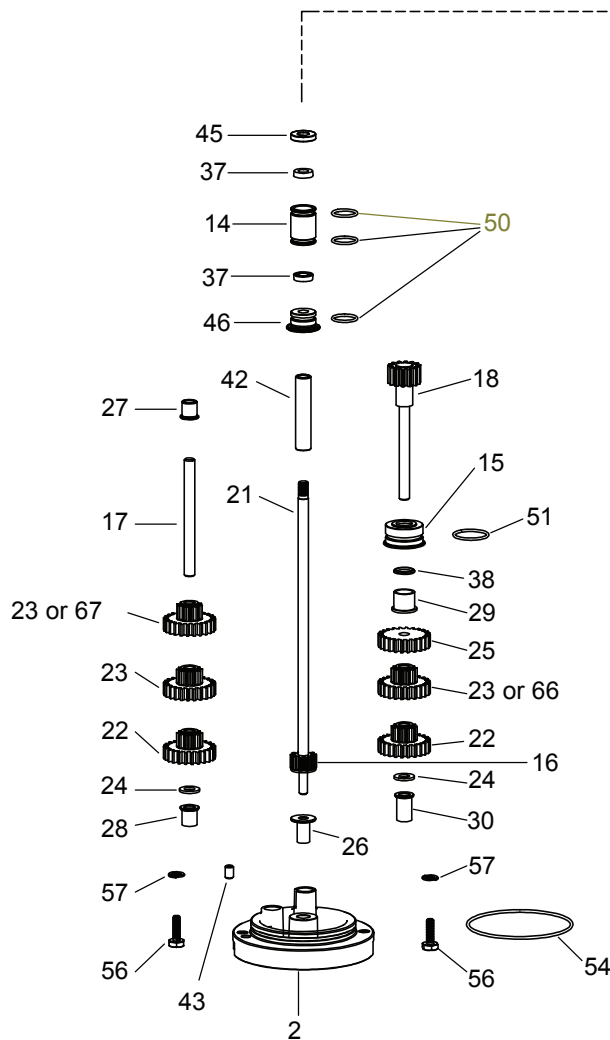

CASTINGS

Illus. No.	316-L STAINLESS		PART DESCRIPTION	QTY/ Unit
	LUBE	FLOW-THRU		
1	601-3S	601-3ST	Gearbox	1
2	602-CS	602-CST	Gearbox Cover	1
3	603-3S	603-3S-ST	Inlet Stem w/2 1/2" Quick Disconnect	1
NI	603-3SOT	603-3SOT-ST	Inlet Stem w/Outside Dia. Threads	1
4*	604-AS		Tee Housing	1
5*	605-S		Nozzle Housing-Dual; Clutch	1
6	606-CS		Name Plate w/Sellers	1
7	607-S		Nozzle (1/4,9/32,5/16,3/8,7/16,1/2,9/16,5/8)	2/3
8	609-3S		Stator-Standard	1
9	610-S		Rotor-Standard	1
10	617-S		Tee Housing Bevel Gear	1
11	618-BS		Nozzle Housing Bevel Gear	1
12*	620-SC		Ring Gear	1

*C.I.P. use - see back page

✓ Options - see back page

COMPONENT PARTS

Illus. No.	LUBRICATED		FLOW-THRU GEARBOX	PART DESCRIPTION	QTY/ Unit
	GEARBOX	ALL MACHINES			
13	608			Stream Straightener	2/3
14	611-3B		N/A	Rotor Shaft Seal Housing	1
15	613-S			Final Shaft Bearing Retainer	1
16	614-A			Rotor Shaft Pinion Gear Sub-Assy	1
17	615			Idler Shaft	1
18	616-SA			Final Shaft & Pinion Assembly	1
19	619			Bevel Gear Snap Ring	1
20	621			Ring Gear Retaining Ring	1
21	622-A			Rotor Shaft Assembly	1
NI	N/A		623-3T	Idler Gear Bearing - PTFE Only	5
22	623-AS		623-AST	Idler Gear - 10T/24T lower	2
23	623-SS		623-SST	Idler Gear - 10T/24T upper	3
24	623-W			Idler Gear Thrust Washer	2
25	624-SS			24T Final Shaft Drive Gear	1
26	626-A		626-AT	Rotor Shaft Thrust Bearing	1
27	627		627-T	Idler Shaft Upper Bearing	1
28	628		628-T	Idler Shaft Lower Bearing	1
29	629-A		629-AT	Final Shaft Upper Bearing	1
30	630		630-T	Final Shaft Lower Bearing	1
31	631			Tee Housing Bearing	2
32	632			Tee Housing Bearing Cup	2
33	633			Nozzle Housing Bearing	2
34	634			Nozzle Housing Bearing Cup	2
35	635-TG			Tee Housing Seal	2
36	636-TG			Nozzle Housing Seal	2
37	641-TG		N/A	Rotor Shaft Seal	3
38	643-ATG		N/A	Final Shaft Seal	1
39	645-3			Stator Retaining Ring	1
40	650-3			Gearbox Bolt	3
41	652-3			Gearbox Bolt Lockwasher	3
42	655-A			Rotor Shaft Spacer	1
43	658			Gearbox Cover Dowel	1
44‡	658-A			618 Bevel Gear Drive Pin	1
45	659-3		N/A	Seal Housing Spacer	1
46	660-3A			Center Carbide Bearing Sub-Assy	1
47	660-DX		660-D	Upper Carbide Bearing Sub-Assy	1
48	664			Strainer	1

N/A = Not Applicable NI = Not Illustrated

‡ Pin drive units only

O-RINGS

Illus. No.	VITON		PART DESCRIPTION	QTY/ Unit
	ETHYLENE PROPYLENE			
49	637-BV	637-BE	Clutch O-Ring: 3" I.D. x 3/16"	1
50	639-V	639-E	611-3A, 660-3A O-Ring	1/3
51	640-V	640-E	613 O-Ring	1
52	641-3V	641-3E	Gearbox Screw O-Ring	3
53	642-3V	642-3E	Gearbox Stem O-Ring	1
54	644-V	644-E	Gearbox Cover O-Ring	1
55	662-V	662-E	660-D, 660-DX O-Ring	1

FASTENERS

	STAINLESS	PART DESCRIPTION	QTY/ Unit
56	646-AS	Gearbox Cover Bolt 3/4"	2
57	647-S	Lockwasher	5
58	648-AS	Name Plate Bolt	2
59	654-S	Rotor Retaining Nut	1

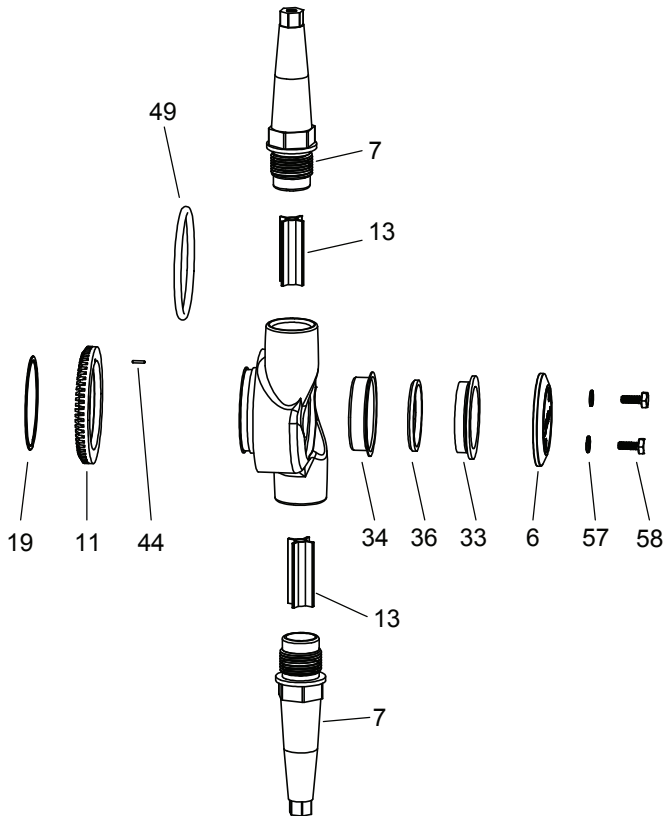

CONFIGURATION OPTIONS

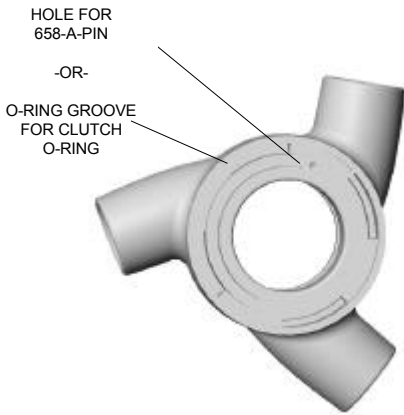

NOZZLE HOUSINGS			
Illus. No.	STAINLESS	PART DESCRIPTION	QTY/Unit
NI	605-SC	Nozzle Housing Dual; Clutch w/CIP	1
NI	605-BS	Nozzle Housing Dual; Pin Drive	1
NI	605-BSC	Nozzle Housing Dual; Pin Drive w/CIP	1
NI	605-TS	Nozzle Housing Triple; Clutch	1
NI	605-TSC	Nozzle Housing Triple; Clutch w/CIP	1
NI	605-BTS	Nozzle Housing Triple; Pin Drive	1
NI	605-BTSC	Nozzle Housing Triple; Pin Drive w/CIP	1

CIP (Clean-In-Place) Parts			
Illus. No.	STAINLESS	PART DESCRIPTION	QTY/Unit
60	607-SRB	Self Rinse Nozzle Assembly	1
NI	604-ASC	Tee Housing w/CIP Holes	1
NI	620-S	Ring Gear w/CIP Slots	1
NI	SEE ABOVE FOR LIST OF NOZZLE HOUSINGS with CIP		1



61



62

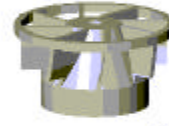

63



64

STATORS			
Illus. No.	STAINLESS	PART DESCRIPTION	QTY/Unit
61	609-3LPS	Stator- Low Pressure	1
62	609-3LMS	Stator- Modified Low Pressure	1
63	609-3HPS	Stator- High Pressure	1
64	609-3HV1S	Stator- High Volume	1



22



23



66



67



65

GEARSETS for 273:1 & 655:1 gear ratios				273	665
Illus. No.	OILITE BEARING	PTFE BEARING	PART DESCRIPTION	QTY	QTY
22	623-AS	623-AST	Idler Gear- 10T/24T Lower	2	2
23	623-SS	623-SST	Idler Gear- 10T/24T Upper	1	3
66	623-BS	623-BST	Idler Gear- 17T/24T for 273:1 Gear Ratio	1	0
67	623-CS	623-CST	Idler Gear- 10T/17T for 273:1 Gear Ratio	1	0
