

THIS PRINT IS AND CONTAINS PROPRIETARY INFORMATION OWNED EXCLUSIVELY BY SELLERS CLEANING SYSTEMS AND CLOUD TANK COMPANY. THIS RESTRICTION INCLUDES, BUT IS NOT LIMITED TO, THE CONDITION THAT THIS PRINT WILL ONLY BE USED AS A RECORD OR TO IDENTIFY OR INSPECT PARTS OR FOR OTHER INFORMATION PURPOSES, AND WILL NOT BE USED TO MANUFACTURE OR PROCURE THE MANUFACTURE OF THE PARTS SHOWN IN THIS PRINT BY ANY OTHER SOURCE THAN SELLERS CLEANING SYSTEMS AND CLOUD TANK COMPANY.

THIS DRAWING IS APPROVED FOR UNCONTROLLED DISTRIBUTION

AS A RESULT OF SELLERS CLEANING SYSTEMS CONSTANT PRODUCT IMPROVEMENT PROGRAM, PRODUCT CHANGES MAY OCCUR. AS SUCH, SELLERS CLEANING SYSTEMS RESERVES THE RIGHT TO CHANGE PRODUCT WITHOUT PRIOR WRITTEN NOTIFICATION

WWW.SELLERSCLEAN.COM

TITLE

ORBI-G3

DWG NO

CD75-1858

REV

C

CAGE NO

96046

SHEET 2 OF 3



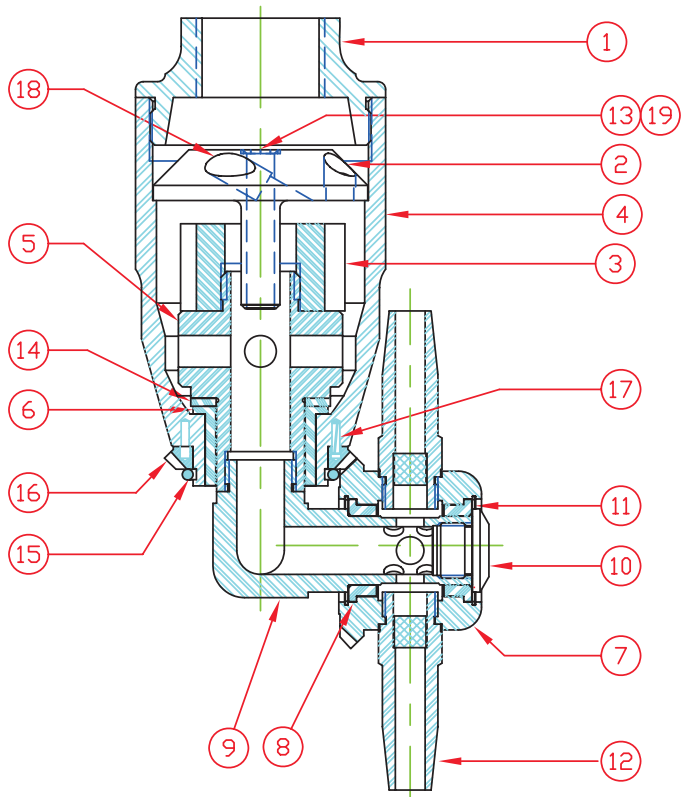

TORQUE CHART	
ITEM NUMBER	TORQUE SPECIFICATIONS
①	60 FT-LBS
⑤	20 FT-LBS
⑩	20 IN-LBS
⑫	15 FT-LBS

NOTES:

- 1) APPLY A SMALL AMOUNT OF NEVER SEEZ LUBRICANT (625-03561) TO ALL THREADS AT ASSEMBLY TO PREVENT GALLING.
- 2) ADJUST THE SPEED OF THE UNIT BY USING OTHER SIZE PLUGS WHICH ARE LISTED BELOW

PLUG NO.	HOLE ϕ
75-1455-A	.063
75-1455-B	.093
75-1455-C	.125
75-1455-D	.140
75-1455-G	.078

- 3) AVAILABLE NOZZLES BASED ON MODEL NUMBER

MODEL NO	NOZZLE
75-1858	75-1849AA
75-1858LP	75-1849AA
75-1858C	75-1849CA
75-1858CLP	75-1849CA

ITEM NO.	QTY REQD	PART OR IDENTIFYING NO.	NOMENCLATURE OR DESCRIPTION	MATERIAL/SPECIFICATION
19	1	7-33-1	PLUG,SOLID	CRES
18	4	75-1455-C	PLUG, BYPASS, ϕ .125	18-8 CRES
17	1	75-1856	PIN, ROLL, ϕ .066	302 CRES
16	1	75-1852	GEAR, BEVEL	316 CRES
15	1	75-1855	RING, RETAINING	316 CRES
14	1	75-1863G	WASHER, SHAFT	UHMW-PE
13	1	SEE NOTE 2	PLUG, BYPASS, AS REQUIRED	18-8 CRES
12	2	SEE NOTE 3	NOZZLE ASSEMBLY	316 CRES
11	2	75-1847	RING, RETAINING	302 CRES
10	1	75-1844	CAP, SHAFT	316 CRES
9	1	75-1859	SHAFT, ELBOW	316 CRES
8	2	75-1846	BUSHING, FLANGED	UHMW-PE
7	1	75-1851	BODY, NOZZLE, GEARED	316 CRES
6	1	75-1408	BUSHING, SHAFT	PTFE
5	1	75-1854	SHAFT, VERTICAL	316 CRES
4	1	75-1853	BODY, MAIN	316 CRES
3	1	75-1801SS	ROTOR, 6 TOOTH	316 CRES
2	1	75-1857	MOTOR, WATER, 4 HOLE	316 CRES
1	1	75-1403	CAP, INLET	316 CRES

THIS PRINT IS AND CONTAINS PROPRIETARY INFORMATION OWNED EXCLUSIVELY BY SELLERS CLEANING SYSTEMS AND CLOUD TANK COMPANY. THIS RESTRICTION INCLUDES, BUT IS NOT LIMITED TO, THE CONDITION THAT THIS PRINT WILL ONLY BE USED AS A RECORD OR TO IDENTIFY OR INSPECT PARTS OR FOR OTHER INFORMATION PURPOSES, AND WILL NOT BE USED TO MANUFACTURE OR PROCURE THE MANUFACTURE OF THE PARTS SHOWN IN THIS PRINT BY ANY OTHER SOURCE THAN SELLERS CLEANING SYSTEMS AND CLOUD TANK COMPANY.

THIS DRAWING IS APPROVED FOR UNCONTROLLED DISTRIBUTION
 AS A RESULT OF SELLERS CLEANING SYSTEMS CONSTANT PRODUCT IMPROVEMENT PROGRAM, PRODUCT CHANGES MAY OCCUR, AS SUCH, SELLERS CLEANING SYSTEMS RESERVES THE RIGHT TO CHANGE PRODUCT WITHOUT PRIOR WRITTEN NOTIFICATION

WWW.SELLERSCLEAN.COM

SHEET 3 OF 3

TITLE

ORBI-G3

CAGE NO

96046

DWG NO

CD75-1858

REV

C



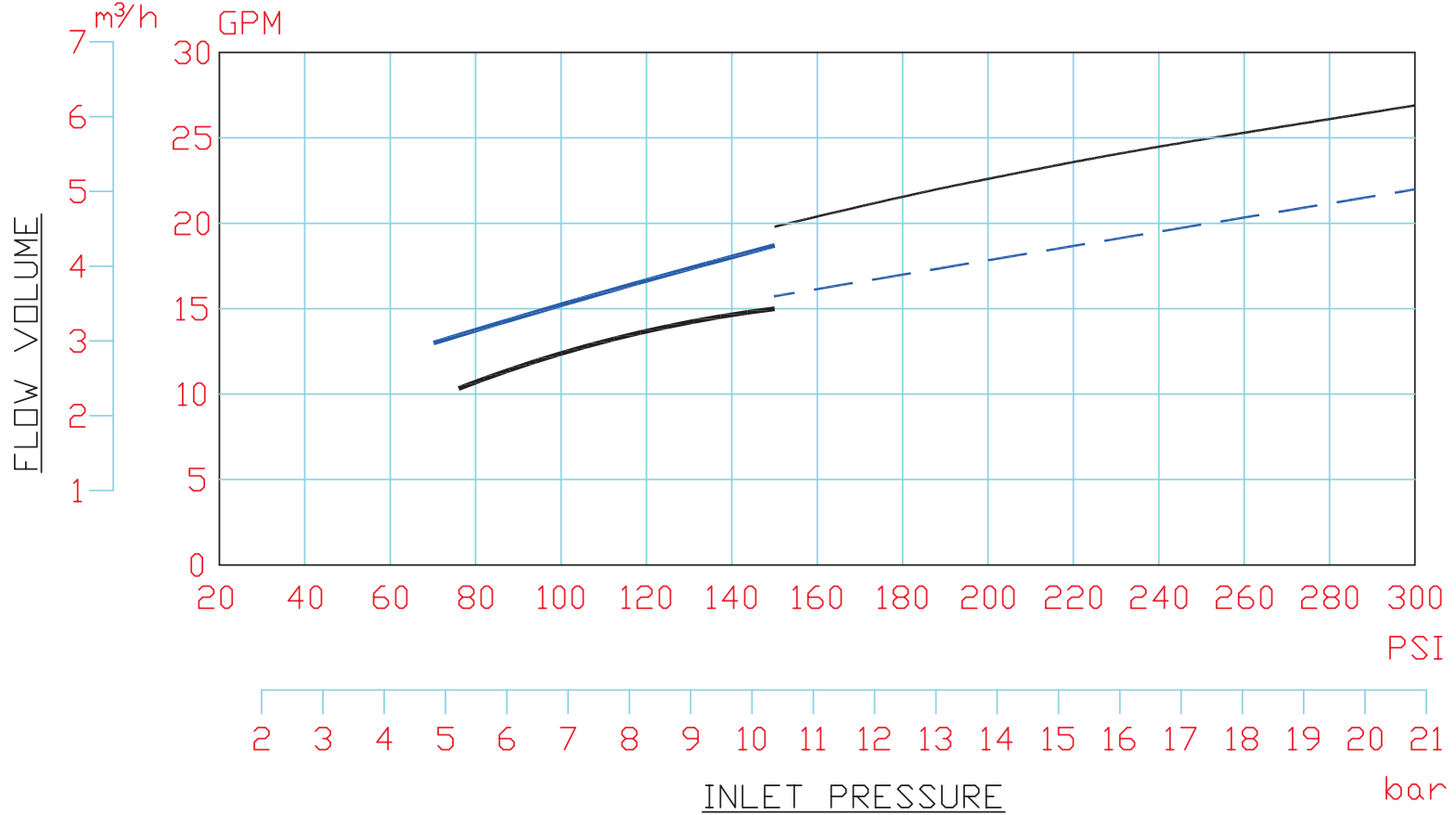

— 75-1858 — 75-1858LP - - - 75-1858C — 75-1858CLP

THIS PRINT IS AND CONTAINS PROPRIETARY INFORMATION OWNED EXCLUSIVELY BY SELLERS CLEANING SYSTEMS AND CLOUD TANK COMPANY. THIS RESTRICTION INCLUDES, BUT IS NOT LIMITED TO, THE CONDITION THAT THIS PRINT WILL ONLY BE USED AS A RECORD OR TO IDENTIFY OR INSPECT PARTS OR FOR OTHER INFORMATION PURPOSES, AND WILL NOT BE USED TO MANUFACTURE OR PROCURE THE MANUFACTURE OF THE PARTS SHOWN IN THIS PRINT BY ANY OTHER SOURCE THAN SELLERS CLEANING SYSTEMS AND CLOUD TANK COMPANY.

THIS DRAWING IS APPROVED FOR UNCONTROLLED DISTRIBUTION
 AS A RESULT OF SELLERS CLEANING SYSTEMS CONSTANT PRODUCT IMPROVEMENT PROGRAM, PRODUCT CHANGES MAY OCCUR. AS SUCH, SELLERS CLEANING SYSTEMS RESERVES THE RIGHT TO CHANGE PRODUCT WITHOUT PRIOR WRITTEN NOTIFICATION

WWW.SELLERSCLEAN.COM

SHEET 1 OF 3

TITLE

ORBI-G3

CAGE NO

96046

DWG NO

CD75-1858

REV

C



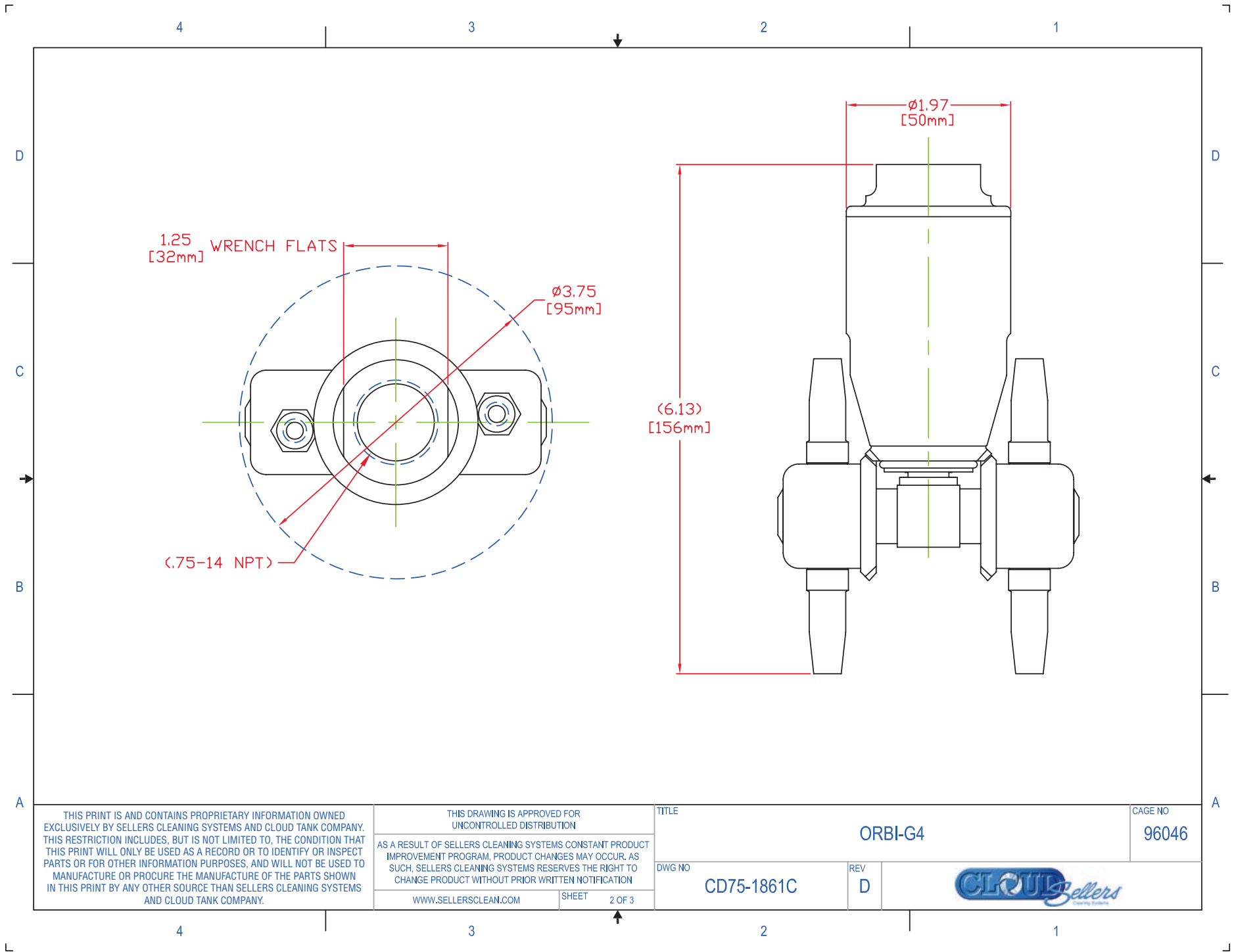

THIS PRINT IS AND CONTAINS PROPRIETARY INFORMATION OWNED EXCLUSIVELY BY SELLERS CLEANING SYSTEMS AND CLOUD TANK COMPANY. THIS RESTRICTION INCLUDES, BUT IS NOT LIMITED TO, THE CONDITION THAT THIS PRINT WILL ONLY BE USED AS A RECORD OR TO IDENTIFY OR INSPECT PARTS OR FOR OTHER INFORMATION PURPOSES, AND WILL NOT BE USED TO MANUFACTURE OR PROCURE THE MANUFACTURE OF THE PARTS SHOWN IN THIS PRINT BY ANY OTHER SOURCE THAN SELLERS CLEANING SYSTEMS AND CLOUD TANK COMPANY.

THIS DRAWING IS APPROVED FOR UNCONTROLLED DISTRIBUTION

AS A RESULT OF SELLERS CLEANING SYSTEMS CONSTANT PRODUCT IMPROVEMENT PROGRAM, PRODUCT CHANGES MAY OCCUR, AS SUCH, SELLERS CLEANING SYSTEMS RESERVES THE RIGHT TO CHANGE PRODUCT WITHOUT PRIOR WRITTEN NOTIFICATION

WWW.SELLERSCLEAN.COM SHEET 2 OF 3

TITLE ORBI-G4 CAGE NO 96046

DWG NO CD75-1861C REV D



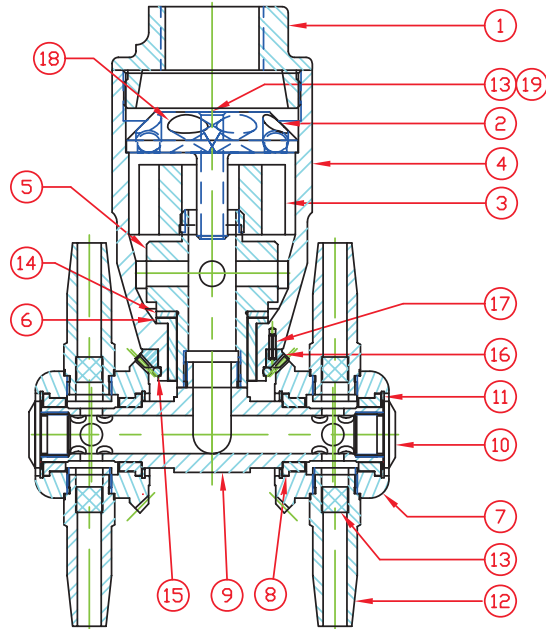
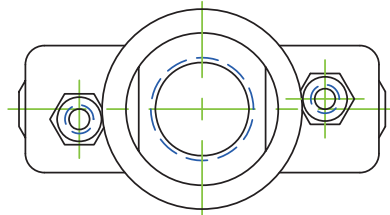

NOTES:

- 1) APPLY A SMALL AMOUNT OF NEVER SEEZ LUBRICANT (625-03561) TO ALL THREADS AT ASSEMBLY TO PREVENT GALLING.
- 2) ADJUST THE SPEED OF THE UNIT BY USING OTHER SIZE PLUGS WHICH ARE LISTED BELOW

PLUG NO.	HOLE ϕ	PLUG NO.	HOLE ϕ	PLUG NO.	HOLE ϕ
75-1455-A	.063	75-1455-C	.125	75-1455-G	.078
75-1455-B	.093	75-1455-D	.140		

3) AVAILABLE NOZZLES BASED ON MODEL NUMBER

MODEL NO	NOZZLE	MODEL NO	NOZZLE
75-1861B	75-1849EA	75-1861CLP	75-1849CA
75-1861BLP	75-1849EA	75-1861D	75-1849DA
75-1861C	75-1849CA	75-1861DLP	75-1849DA

4) ITEM #18

MODEL NO	PLUG NO.	HOLE ϕ
75-1861C	75-1455-D	.140
ALL OTHERS	75-1455-C	.125

ITEM NO.	QTY REQD	PART OR IDENTIFYING NO.	NOMENCLATURE OR DESCRIPTION	MATERIAL/SPECIFICATION
19	1	7-33-1	PLUG,SOLID	CRES
18	4	SEE NOTE 4	PLUG, BYPASS	18-8 CRES
17	1	75-1856	PIN, ROLL, ϕ .062	316 CRES
16	1	75-1852	GEAR, BEVEL	316 CRES
15	1	75-1855	RING, RETAINING	316 CRES
14	1	75-1863G	WASHER	UHMW-PE
13	1	SEE NOTE 2	PLUG, BYPASS, SIZE AS REQUIRED	18-8 CRES
12	4	SEE NOTE 3	NOZZLE ASSEMBLY	316 CRES
11	4	75-1847	RING, RETAINING	302 CRES
10	2	75-1844	CAP, SHAFT	316 CRES
9	1	75-1860	SHAFT, ELBOW	316 CRES
8	4	75-1846	BUSHING	UHMW-PE
7	2	75-1851	BODY, NOZZLE, GEARED	316 CRES
6	1	75-1862	BUSHING, SHAFT	PTFE
5	1	75-1854	SHAFT, VERTICAL	316 CRES
4	1	75-1853	BODY, MAIN	316 CRES
3	1	75-1801SS	ROTOR, 6 TOOTH	316 CRES
2	1	75-1857	MOTOR, WATER, 4 HOLE	316 CRES
1	1	75-1403	CAP, INLET	316 CRES

TORQUE CHART	
ITEM NUMBER	TORQUE SPECIFICATIONS
①	60 FT-LBS
⑤	20 FT-LBS
⑩	20 IN-LBS
⑫	15 FT-LBS

THIS PRINT IS AND CONTAINS PROPRIETARY INFORMATION OWNED EXCLUSIVELY BY SELLERS CLEANING SYSTEMS AND CLOUD TANK COMPANY. THIS RESTRICTION INCLUDES, BUT IS NOT LIMITED TO, THE CONDITION THAT THIS PRINT WILL ONLY BE USED AS A RECORD OR TO IDENTIFY OR INSPECT PARTS OR FOR OTHER INFORMATION PURPOSES, AND WILL NOT BE USED TO MANUFACTURE OR PROCURE THE MANUFACTURE OF THE PARTS SHOWN IN THIS PRINT BY ANY OTHER SOURCE THAN SELLERS CLEANING SYSTEMS AND CLOUD TANK COMPANY.

THIS DRAWING IS APPROVED FOR UNCONTROLLED DISTRIBUTION
 AS A RESULT OF SELLERS CLEANING SYSTEMS CONSTANT PRODUCT IMPROVEMENT PROGRAM. PRODUCT CHANGES MAY OCCUR. AS SUCH, SELLERS CLEANING SYSTEMS RESERVES THE RIGHT TO CHANGE PRODUCT WITHOUT PRIOR WRITTEN NOTIFICATION
 WWW.SELLERSCLEAN.COM SHEET 3 OF 3

TITLE ORBI-G4		CAGE NO 96046
DWG NO CD75-1861C	REV D	

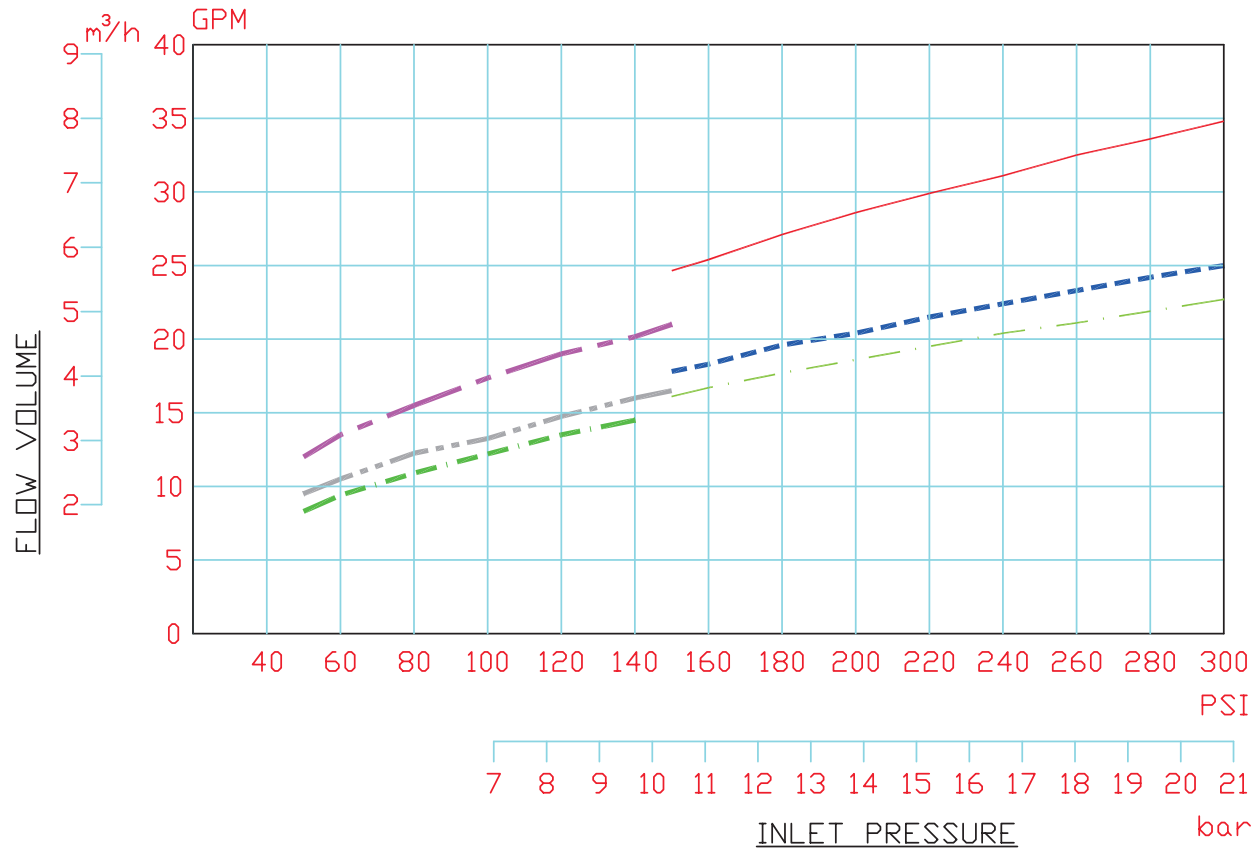

- .172" DIA. NOZZLE 75-1861C 150-300 PSI
- - .172" DIA. NOZZLE 75-1861CLP 50-140 PSI
- - - .140" DIA. NOZZLE 75-1861B 150-300 PSI
- - - .140" DIA. NOZZLE 75-1861BLP 50-140 PSI
- · - · .125" DIA. NOZZLE 75-1861D 150-300 PSI
- · - · .125" DIA. NOZZLE 75-1861DLP 50-140 PSI

THIS PRINT IS AND CONTAINS PROPRIETARY INFORMATION OWNED EXCLUSIVELY BY SELLERS CLEANING SYSTEMS AND CLOUD TANK COMPANY. THIS RESTRICTION INCLUDES, BUT IS NOT LIMITED TO, THE CONDITION THAT THIS PRINT WILL ONLY BE USED AS A RECORD OR TO IDENTIFY OR INSPECT PARTS OR FOR OTHER INFORMATION PURPOSES, AND WILL NOT BE USED TO MANUFACTURE OR PROCURE THE MANUFACTURE OF THE PARTS SHOWN IN THIS PRINT BY ANY OTHER SOURCE THAN SELLERS CLEANING SYSTEMS AND CLOUD TANK COMPANY.

THIS DRAWING IS APPROVED FOR UNCONTROLLED DISTRIBUTION
 AS A RESULT OF SELLERS CLEANING SYSTEMS CONSTANT PRODUCT IMPROVEMENT PROGRAM, PRODUCT CHANGES MAY OCCUR, AS SUCH, SELLERS CLEANING SYSTEMS RESERVES THE RIGHT TO CHANGE PRODUCT WITHOUT PRIOR WRITTEN NOTIFICATION

WWW.SELLERSCLEAN.COM

SHEET 1 OF 3

TITLE

ORBI-G4

CAGE NO

96046

DWG NO

CD75-1861C

REV

C

