

<p>THIS PRINT IS AND CONTAINS PROPRIETARY INFORMATION OWNED EXCLUSIVELY BY SELLERS CLEANING SYSTEMS AND CLOUD TANK COMPANY. THIS RESTRICTION INCLUDES, BUT IS NOT LIMITED TO, THE CONDITION THAT THIS PRINT WILL ONLY BE USED AS A RECORD OR TO IDENTIFY OR INSPECT PARTS OR FOR OTHER INFORMATION PURPOSES, AND WILL NOT BE USED TO MANUFACTURE OR PROCURE THE MANUFACTURE OF THE PARTS SHOWN IN THIS PRINT BY ANY OTHER SOURCE THAN SELLERS CLEANING SYSTEMS AND CLOUD TANK COMPANY.</p>	<p>THIS DRAWING IS APPROVED FOR UNCONTROLLED DISTRIBUTION</p>		<p>TITLE <b>2 NOZZLE TANKMAN</b></p>		<p>CAGE NO <b>96046</b></p>
	<p>AS A RESULT OF SELLERS CLEANING SYSTEMS CONSTANT PRODUCT IMPROVEMENT PROGRAM, PRODUCT CHANGES MAY OCCUR. AS SUCH, SELLERS CLEANING SYSTEMS RESERVES THE RIGHT TO CHANGE PRODUCT WITHOUT PRIOR WRITTEN NOTIFICATION</p>		<p>DWG NO <b>CD80-100</b></p>	<p>REV <b>D</b></p>	
	<p>WWW.SELLERSCLEAN.COM</p>	<p>SHEET 1 OF 3</p>			

8

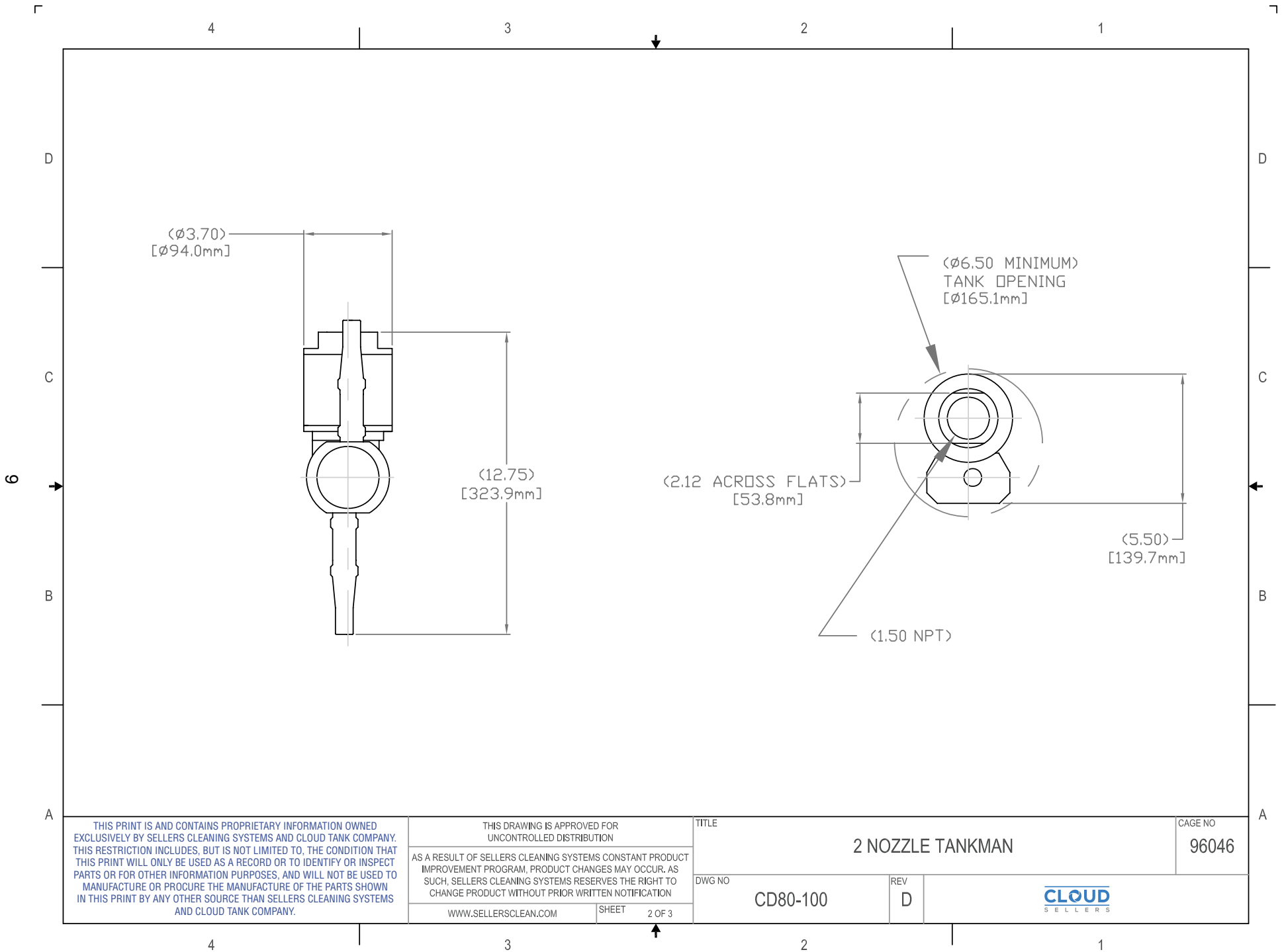

THIS PRINT IS AND CONTAINS PROPRIETARY INFORMATION OWNED EXCLUSIVELY BY SELLERS CLEANING SYSTEMS AND CLOUD TANK COMPANY. THIS RESTRICTION INCLUDES, BUT IS NOT LIMITED TO, THE CONDITION THAT THIS PRINT WILL ONLY BE USED AS A RECORD OR TO IDENTIFY OR INSPECT PARTS OR FOR OTHER INFORMATION PURPOSES, AND WILL NOT BE USED TO MANUFACTURE OR PROCURE THE MANUFACTURE OF THE PARTS SHOWN IN THIS PRINT BY ANY OTHER SOURCE THAN SELLERS CLEANING SYSTEMS AND CLOUD TANK COMPANY.

THIS DRAWING IS APPROVED FOR UNCONTROLLED DISTRIBUTION

AS A RESULT OF SELLERS CLEANING SYSTEMS CONSTANT PRODUCT IMPROVEMENT PROGRAM, PRODUCT CHANGES MAY OCCUR. AS SUCH, SELLERS CLEANING SYSTEMS RESERVES THE RIGHT TO CHANGE PRODUCT WITHOUT PRIOR WRITTEN NOTIFICATION

WWW.SELLERSCLEAN.COM SHEET 2 OF 3

TITLE		CAGE NO	
2 NOZZLE TANKMAN		96046	
DWG NO	REV	CLOUD SELLERS	
CD80-100	D		

PART No.	ITEM #1	ITEM #6	ITEM #9	ITEM #19	ITEM #20
80-100	80-101	80-106	80-109-SS	80-117	J6-115-GA
80-100-HA	80-101	80-106	80-109-SS	80-117	J6-115-HA
80-100-HA4	80-101	80-306	80-209-SS	80-117	J6-115-HA
80-100-FA	80-101	80-106	80-109-SS	80-117-LF	J6-115-FA

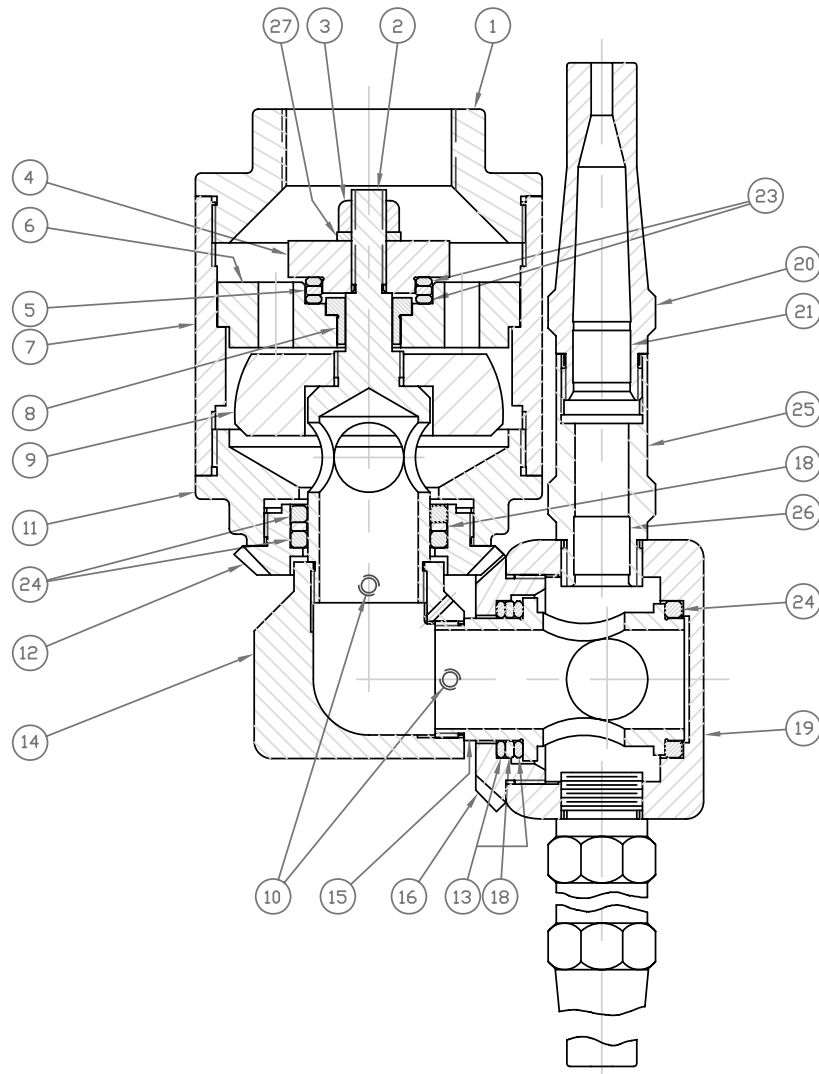

**NOTES:**

- WEIGHT PER UNIT = 15 LBS, SHIPPING WEIGHT = 19 LBS
- APPLY A SMALL AMOUNT OF NEVER-SEIZE LUBRICANT (625-03561) TO ALL THREADS AT ASSEMBLY TO PREVENT GALLING.
- USE THE FOLLOWING TORQUES FOR ASSEMBLY:  
 ITEMS #12 AND #16 TO 100 FT/LBS  
 ITEM #1 WHILE HOLDING ITEM #11 TO 75 FT/LBS  
 ITEM #10 TO 20 IN/LBS  
 ITEM #20 WHILE HOLDING ITEM #19 TO 80 FT/LBS  
 ITEM #3 TO 20 FT/LBS.
- SPARE PARTS KIT NUMBER 80-120-SPK  
 PARTS FOR THE KIT ARE IDENTIFIED WITH AN ●

●	27	1	20-14-1	WASHER,SPLIT,LOCK,,375	18-8 SS
●	26	REF	80-122	VANE,STABILIZER (IN #25)	316 SS
●	25	2	80-123	EXTENSION,NOZZLE ASSEMBLY	316 SS
●	24	3	80-119	WASHER,RADIAL	UHMW-PE
●	23	2	J6-239	WASHER THRUST	UHMW-PE
●	21	REF	80-122	STRAIGHTENER,STREAM (IN #20)	316 SS
●	20	2	SEE CHART	NOZZLE ASSEMBLY	316 SS
●	19	1	SEE CHART	BODY,NOZZLE,DUAL	316 SS
●	18	2	80-116	WASHER,THRUST	TEFLON
●	16	1	80-114-EP	GEAR,44 TOOTH	316 SS
●	15	1	80-113	SHAFT,NOZZLE BODY,HORIZ	316 SS
●	14	1	80-112	ELBOW	316 SS
●	13	2	J6-238	WASHER,THRUST	UHMW-PE
●	12	1	80-111-EP	GEAR,45 TOOTH	316 SS
●	11	1	80-110	CAP,LOWER BODY	316 SS
●	10	2	74-324	SCREW,SET	18-8 SS
●	9	1	SEE CHART	IMPELLER,RH,DUAL	316 SS
●	8	1	80-108	BUSHING,VERTICAL SHAFT	TEFLON
●	7	1	80-107	BODY,OUTER	316 SS
●	6	1	SEE CHART	DISC,INLET,DUAL	316 SS
●	5	1	80-105	WASHER,THRUST	TEFLON
●	4	1	80-104	CAP,VERTICAL SHAFT	316 SS
●	3	1	15-23-1	NUT,HEX,,375-16	18-8 SS
●	2	1	80-102	SHAFT,VERTICAL	316 SS
●	1	1	SEE CHART	CAP,INLET	316 SS

ITEM NO.	QTY REQD	PART OR IDENTIFYING NO.	NOMENCLATURE OR DESCRIPTION	MATERIAL/SPECIFICATION
----------	----------	-------------------------	-----------------------------	------------------------

THIS PRINT IS AND CONTAINS PROPRIETARY INFORMATION OWNED EXCLUSIVELY BY SELLERS CLEANING SYSTEMS AND CLOUD TANK COMPANY. THIS RESTRICTION INCLUDES, BUT IS NOT LIMITED TO, THE CONDITION THAT THIS PRINT WILL ONLY BE USED AS A RECORD OR TO IDENTIFY OR INSPECT PARTS OR FOR OTHER INFORMATION PURPOSES, AND WILL NOT BE USED TO MANUFACTURE OR PROCURE THE MANUFACTURE OF THE PARTS SHOWN IN THIS PRINT BY ANY OTHER SOURCE THAN SELLERS CLEANING SYSTEMS AND CLOUD TANK COMPANY.

THIS DRAWING IS APPROVED FOR UNCONTROLLED DISTRIBUTION  
 AS A RESULT OF SELLERS CLEANING SYSTEMS CONSTANT PRODUCT IMPROVEMENT PROGRAM, PRODUCT CHANGES MAY OCCUR. AS SUCH, SELLERS CLEANING SYSTEMS RESERVES THE RIGHT TO CHANGE PRODUCT WITHOUT PRIOR WRITTEN NOTIFICATION  
 WWW.SELLERSCLEAN.COM SHEET 3 OF 3

TITLE			CAGE NO
2 NOZZLE TANKMAN			96046
DWG NO	REV		
CD80-100	D		

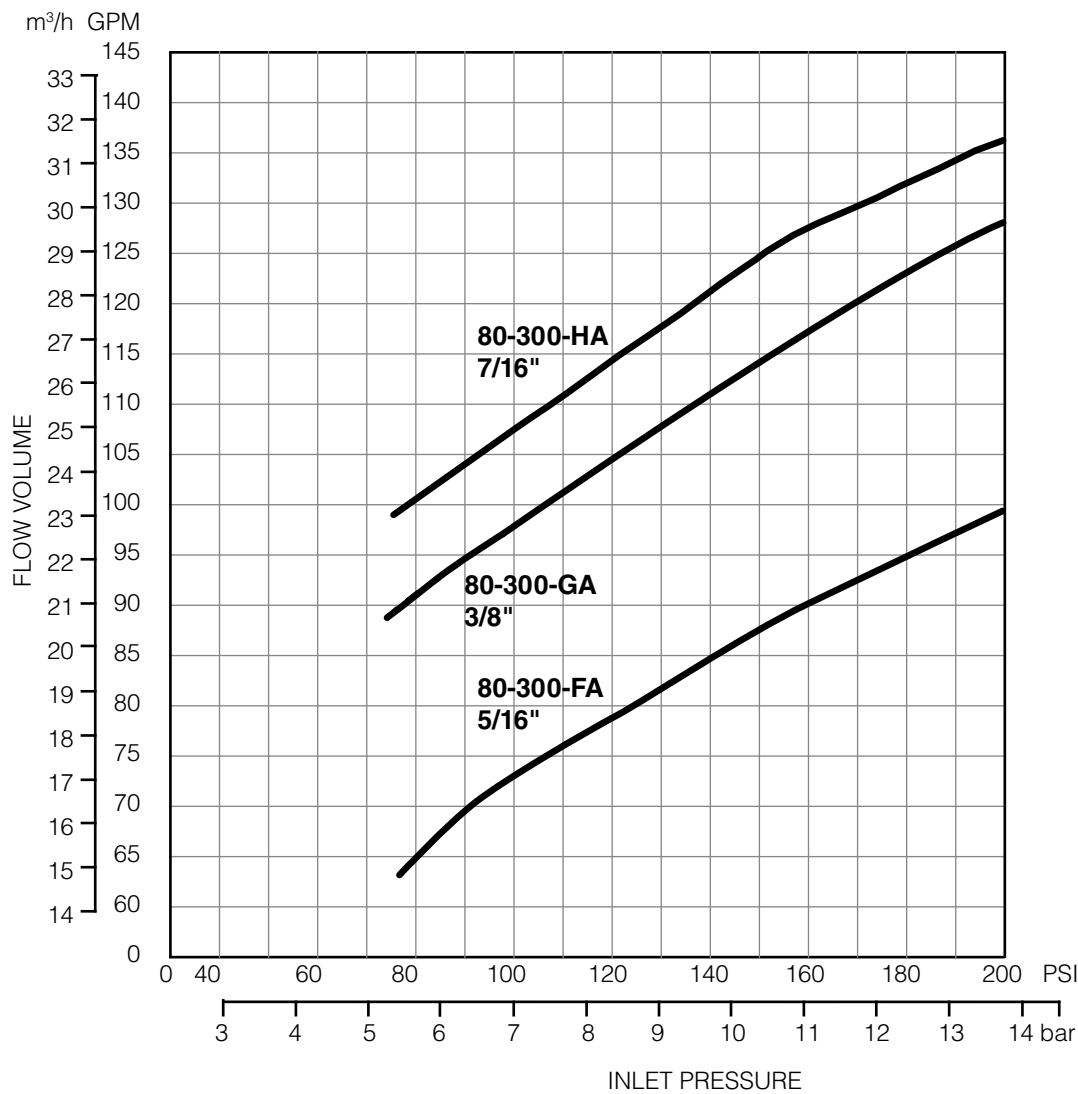

THIS PRINT IS AND CONTAINS PROPRIETARY INFORMATION OWNED EXCLUSIVELY BY SELLERS CLEANING SYSTEMS AND CLOUD TANK COMPANY. THIS RESTRICTION INCLUDES, BUT IS NOT LIMITED TO, THE CONDITION THAT THIS PRINT WILL ONLY BE USED AS A RECORD OR TO IDENTIFY OR INSPECT PARTS OR FOR OTHER INFORMATION PURPOSES, AND WILL NOT BE USED TO MANUFACTURE OR PROCURE THE MANUFACTURE OF THE PARTS SHOWN IN THIS PRINT BY ANY OTHER SOURCE THAN SELLERS CLEANING SYSTEMS AND CLOUD TANK COMPANY.

THIS DRAWING IS APPROVED FOR UNCONTROLLED DISTRIBUTION  
 AS A RESULT OF SELLERS CLEANING SYSTEMS CONSTANT PRODUCT IMPROVEMENT PROGRAM, PRODUCT CHANGES MAY OCCUR, AS SUCH, SELLERS CLEANING SYSTEMS RESERVES THE RIGHT TO CHANGE PRODUCT WITHOUT PRIOR WRITTEN NOTIFICATION  
 WWW.SELLERSCLEAN.COM SHEET 1 OF 3

TITLE <b>3 NOZZLE TANKMAN</b>		CAGE NO <b>96046</b>
DWG NO <b>CD80-300</b>	REV <b>D</b>	

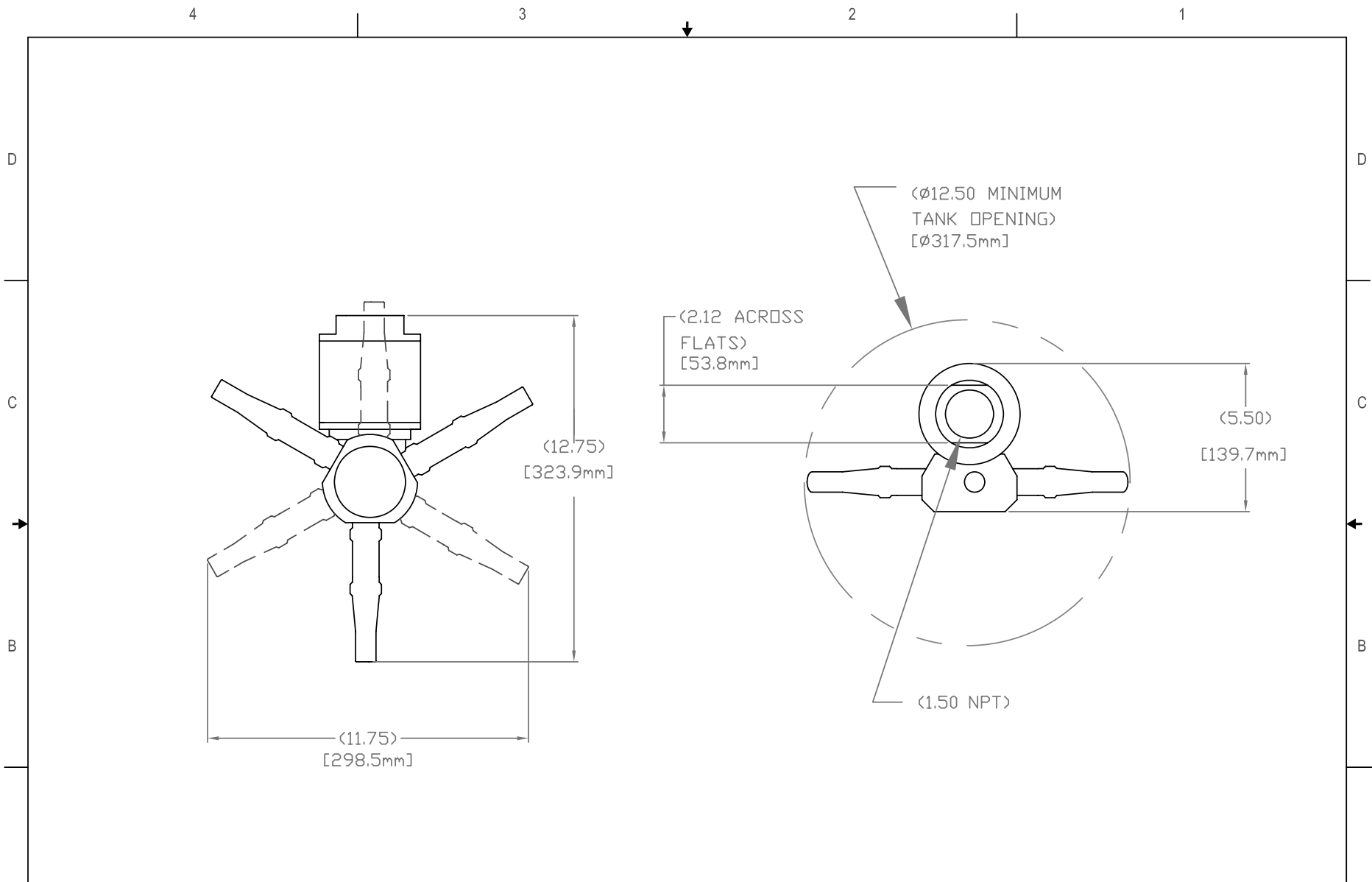

12

THIS PRINT IS AND CONTAINS PROPRIETARY INFORMATION OWNED EXCLUSIVELY BY SELLERS CLEANING SYSTEMS AND CLOUD TANK COMPANY. THIS RESTRICTION INCLUDES, BUT IS NOT LIMITED TO, THE CONDITION THAT THIS PRINT WILL ONLY BE USED AS A RECORD OR TO IDENTIFY OR INSPECT PARTS OR FOR OTHER INFORMATION PURPOSES, AND WILL NOT BE USED TO MANUFACTURE OR PROCURE THE MANUFACTURE OF THE PARTS SHOWN IN THIS PRINT BY ANY OTHER SOURCE THAN SELLERS CLEANING SYSTEMS AND CLOUD TANK COMPANY.

THIS DRAWING IS APPROVED FOR UNCONTROLLED DISTRIBUTION

AS A RESULT OF SELLERS CLEANING SYSTEMS CONSTANT PRODUCT IMPROVEMENT PROGRAM, PRODUCT CHANGES MAY OCCUR, AS SUCH, SELLERS CLEANING SYSTEMS RESERVES THE RIGHT TO CHANGE PRODUCT WITHOUT PRIOR WRITTEN NOTIFICATION

WWW.SELLERSCLEAN.COM SHEET 2 OF 3

TITLE		CAGE NO
3 NOZZLE TANKMAN		96046
DWG NO	REV	
CD80-300	D	

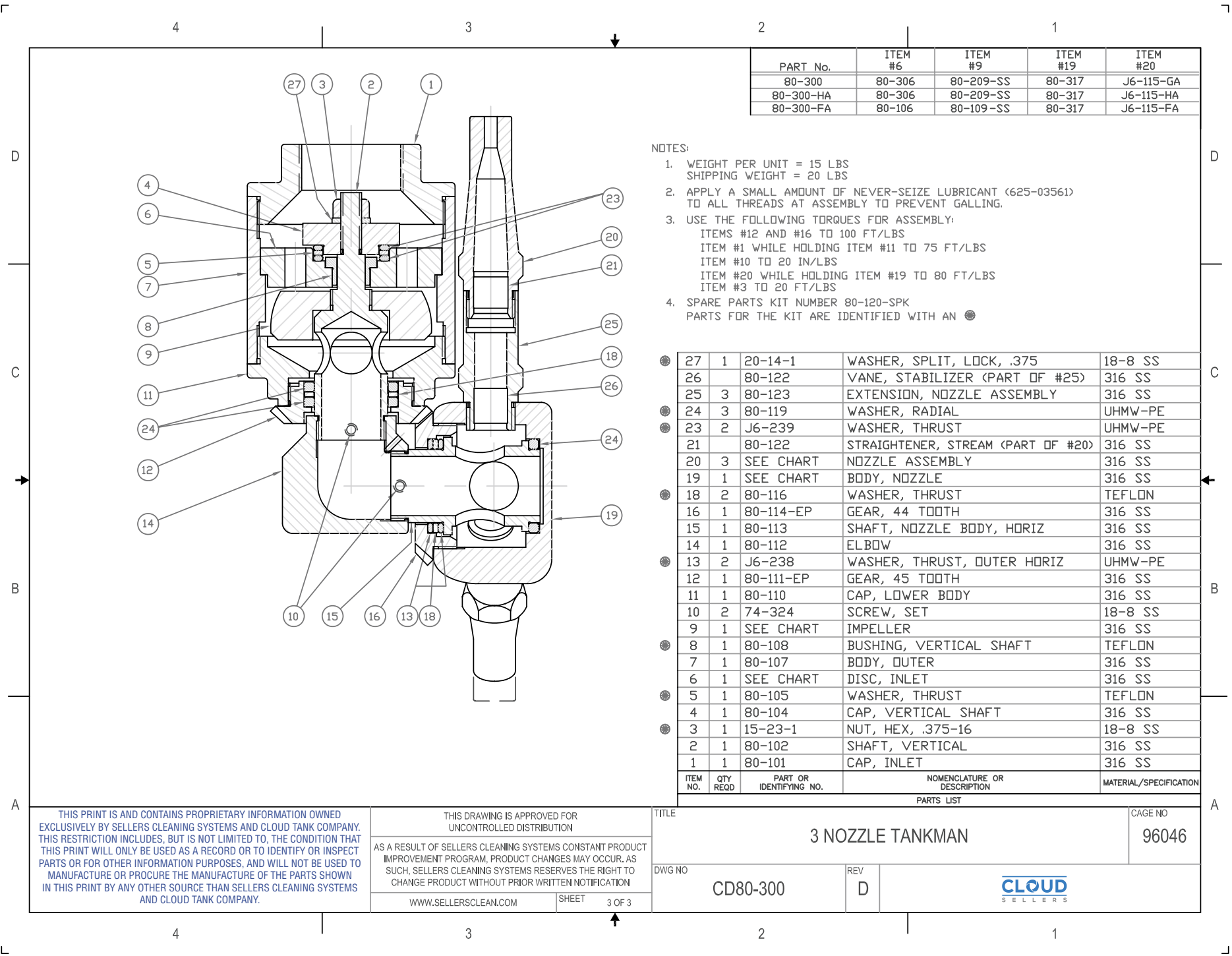

PART No.	ITEM #6	ITEM #9	ITEM #19	ITEM #20
80-300	80-306	80-209-SS	80-317	J6-115-GA
80-300-HA	80-306	80-209-SS	80-317	J6-115-HA
80-300-FA	80-106	80-109-SS	80-317	J6-115-FA

- NOTES:
- WEIGHT PER UNIT = 15 LBS  
SHIPPING WEIGHT = 20 LBS
  - APPLY A SMALL AMOUNT OF NEVER-SEIZE LUBRICANT (625-03561) TO ALL THREADS AT ASSEMBLY TO PREVENT GALLING.
  - USE THE FOLLOWING TORQUES FOR ASSEMBLY:  
ITEMS #12 AND #16 TO 100 FT/LBS  
ITEM #1 WHILE HOLDING ITEM #11 TO 75 FT/LBS  
ITEM #10 TO 20 IN/LBS  
ITEM #20 WHILE HOLDING ITEM #19 TO 80 FT/LBS  
ITEM #3 TO 20 FT/LBS
  - SPARE PARTS KIT NUMBER 80-120-SPK  
PARTS FOR THE KIT ARE IDENTIFIED WITH AN ●

● 27	1	20-14-1	WASHER, SPLIT, LOCK, .375	18-8 SS
26		80-122	VANE, STABILIZER (PART OF #25)	316 SS
25	3	80-123	EXTENSION, NOZZLE ASSEMBLY	316 SS
● 24	3	80-119	WASHER, RADIAL	UHMW-PE
● 23	2	J6-239	WASHER, THRUST	UHMW-PE
21		80-122	STRAIGHTENER, STREAM (PART OF #20)	316 SS
20	3	SEE CHART	NOZZLE ASSEMBLY	316 SS
19	1	SEE CHART	BODY, NOZZLE	316 SS
● 18	2	80-116	WASHER, THRUST	TEFLON
16	1	80-114-EP	GEAR, 44 TOOTH	316 SS
15	1	80-113	SHAFT, NOZZLE BODY, HORIZ	316 SS
14	1	80-112	ELBOW	316 SS
● 13	2	J6-238	WASHER, THRUST, OUTER HORIZ	UHMW-PE
12	1	80-111-EP	GEAR, 45 TOOTH	316 SS
11	1	80-110	CAP, LOWER BODY	316 SS
10	2	74-324	SCREW, SET	18-8 SS
9	1	SEE CHART	IMPELLER	316 SS
● 8	1	80-108	BUSHING, VERTICAL SHAFT	TEFLON
7	1	80-107	BODY, OUTER	316 SS
6	1	SEE CHART	DISC, INLET	316 SS
● 5	1	80-105	WASHER, THRUST	TEFLON
4	1	80-104	CAP, VERTICAL SHAFT	316 SS
● 3	1	15-23-1	NUT, HEX, .375-16	18-8 SS
2	1	80-102	SHAFT, VERTICAL	316 SS
1	1	80-101	CAP, INLET	316 SS

ITEM NO.	QTY REQD	PART OR IDENTIFYING NO.	NOMENCLATURE OR DESCRIPTION	MATERIAL/SPECIFICATION
----------	----------	-------------------------	-----------------------------	------------------------

THIS PRINT IS AND CONTAINS PROPRIETARY INFORMATION OWNED EXCLUSIVELY BY SELLERS CLEANING SYSTEMS AND CLOUD TANK COMPANY. THIS RESTRICTION INCLUDES, BUT IS NOT LIMITED TO, THE CONDITION THAT THIS PRINT WILL ONLY BE USED AS A RECORD OR TO IDENTIFY OR INSPECT PARTS OR FOR OTHER INFORMATION PURPOSES, AND WILL NOT BE USED TO MANUFACTURE OR PROCURE THE MANUFACTURE OF THE PARTS SHOWN IN THIS PRINT BY ANY OTHER SOURCE THAN SELLERS CLEANING SYSTEMS AND CLOUD TANK COMPANY.

THIS DRAWING IS APPROVED FOR UNCONTROLLED DISTRIBUTION  
AS A RESULT OF SELLERS CLEANING SYSTEMS CONSTANT PRODUCT IMPROVEMENT PROGRAM, PRODUCT CHANGES MAY OCCUR. AS SUCH, SELLERS CLEANING SYSTEMS RESERVES THE RIGHT TO CHANGE PRODUCT WITHOUT PRIOR WRITTEN NOTIFICATION  
WWW.SELLERSCLEAN.COM SHEET 3 OF 3

TITLE		3 NOZZLE TANKMAN		CAGE NO	96046
DWG NO	CD80-300	REV	D		