

NOTES:

1) BALL INFORMATION

TROLL BALL	BALL PATTERN	BALL REF. NO.
75-14-B	'B'	75F-1428
75-14-C	'C'	75F-1443
75-14-D	'D'	75F-1444
75-14-E	'E'	75F-1429
75-14-F	'F'	75F-1432
75-14-G	'G'	75F-1440
75-14-H	'H'	75F-1448

2) USE THE FOLLOWING TORQUES FOR ASSEMBLY:
ITEM #1 WHILE HOLDING ITEM #4 TO 60 FT/LBS

3) PLUG USED IN BYPASS TO SPEED UP UNIT:

PLUG NO.	HOLE Ø
75-1455-B	.093
7-33-1	SOLID

4) APPLY A SMALL AMOUNT OF NEVER-SEEZ LUBRICANT (625-03561) TO ALL THREADS AT ASSEMBLY TO PREVENT GALLING.

5) SPARE PARTS KIT NUMBER 75-14-SPK
PARTS FOR THE KIT ARE IDENTIFIED WITH AN ☼

ITEM NO.	QTY REQD	PART OR IDENTIFYING NO.	NOMENCLATURE OR DESCRIPTION	MATERIAL/SPECIFICATION
☼ 10	1	75-1415	PIN, SPRING	316 SS
9	1	SEE NOTE #3	PLUG	316 SS
8	1	SEE NOTE #1	BALL	316 SS
☼ 7	1	75-1437	SHAFT, TROLL BALL	316 SS
☼ 6	1	75-1408	BUSHING	TEFLON
☼ 5	1	75-1416	WASHER	TEFLON
4	1	75-1467	BODY	316 SS
3	1	75-1445	DISK, ROTOR	TEFLON
2	1	75-1453	MOTOR	316 SS
1	1	75-1403	CAP, INLET	316 SS

THIS PRINT IS AND CONTAINS PROPRIETARY INFORMATION OWNED EXCLUSIVELY BY SELLERS CLEANING SYSTEMS AND CLOUD TANK COMPANY. THIS RESTRICTION INCLUDES, BUT IS NOT LIMITED TO, THE CONDITION THAT THIS PRINT WILL ONLY BE USED AS A RECORD OR TO IDENTIFY OR INSPECT PARTS OR FOR OTHER INFORMATION PURPOSES, AND WILL NOT BE USED TO MANUFACTURE OR PROCURE THE MANUFACTURE OF THE PARTS SHOWN IN THIS PRINT BY ANY OTHER SOURCE THAN SELLERS CLEANING SYSTEMS AND CLOUD TANK COMPANY.

THIS DRAWING IS APPROVED FOR UNCONTROLLED DISTRIBUTION
AS A RESULT OF SELLERS CLEANING SYSTEMS CONSTANT PRODUCT IMPROVEMENT PROGRAM, PRODUCT CHANGES MAY OCCUR. AS SUCH, SELLERS CLEANING SYSTEMS RESERVES THE RIGHT TO CHANGE PRODUCT WITHOUT PRIOR WRITTEN NOTIFICATION
WWW.SELLERSCLEAN.COM SHEET 3 OF 3

TITLE 2" TROLL BALL, PIN		CAGE NO 96046
DWG NO CD75-14-X	REV B	

NOTES:

1) BALL INFORMATION

TROLL BALL	BALL PATTERN	BALL REF. NO.
75-14-BB	'B'	75F-1428B
75-14-CB	'C'	75F-1443B
75-14-DB	'D'	75F-1444B
75-14-EB	'E'	75F-1429B
75-14-FB	'F'	75F-1432B
75-14-GB	'G'	75F-1440B
75-14-HB	'H'	75F-1448B

**2) USE THE FOLLOWING TORQUES FOR ASSEMBLY:
ITEM #1 WHILE HOLDING ITEM #4 TO 60 FT/LBS**

3) PLUG USED IN BYPASS TO SPEED UP UNIT:

PLUG NO.	HOLE Ø
75-1455-B	.093
7-33-1	SOLID

**4) APPLY A SMALL AMOUNT OF NEVER-SEEZ LUBRICANT (625-03561)
TO ALL THREADS AT ASSEMBLY TO PREVENT GALLING.**

**5) SPARE PARTS KIT NUMBER 75-14B-SPK
PARTS FOR THE KIT ARE IDENTIFIED WITH AN ⦿**

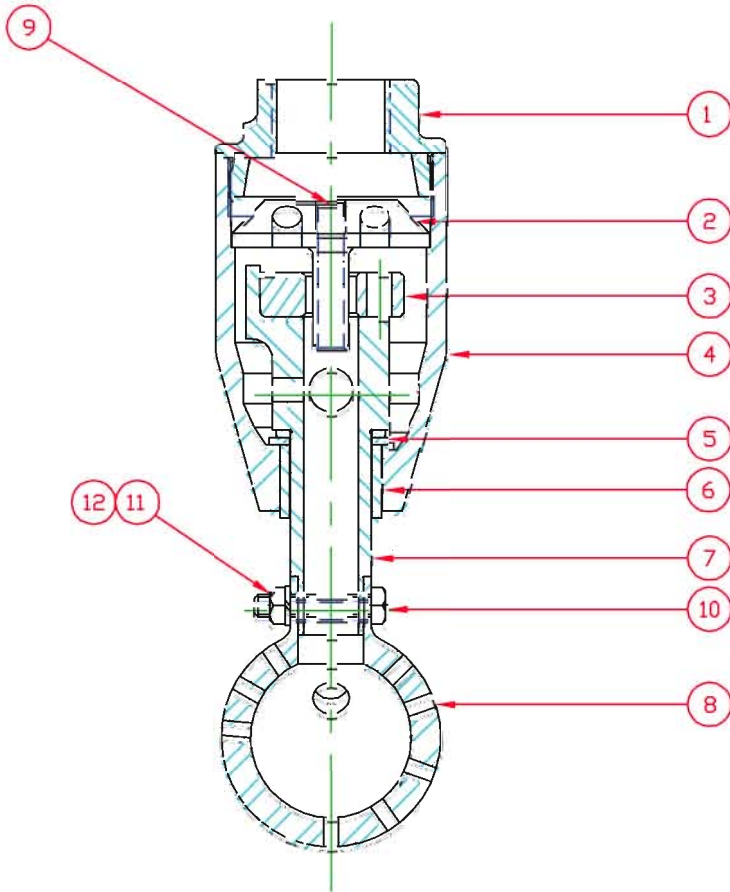

ITEM NO.	QTY REQ'D	PART OR IDENTIFYING NO.	NOMENCLATURE OR DESCRIPTION	MATERIAL/SPECIFICATION
⦿ 12	1	108331	NUT, HEX, #10-32 THD.	18-8 SS
⦿ 11	1	20-12-1	LOCK WASHER, SPLIT #10 THD	18-8 SS
⦿ 10	1	1-401-1	SCREW, HX. HD. #10-32 X 1.00	18-8 SS
9	1	SEE NOTE #3	PLUG	316 SS
8	1	SEE NOTE #1	BALL	316 SS
⦿ 7	1	75-1437B	SHAFT, TROLL BALL	316 SS
⦿ 6	1	75-1408	BUSHING	TEFLON
⦿ 5	1	75-1416	WASHER	TEFLON
⦿ 4	1	75-1467	BODY	316 SS
⦿ 3	1	75-1445	DISK, ROTOR	TEFLON
⦿ 2	1	75-1453	MOTOR	316 SS
1	1	75-1403	CAP. INLET	316 SS

THIS PRINT IS AND CONTAINS PROPRIETARY INFORMATION OWNED EXCLUSIVELY BY SELLERS CLEANING SYSTEMS AND CLOUD TANK COMPANY. THIS RESTRICTION INCLUDES, BUT IS NOT LIMITED TO, THE CONDITION THAT THIS PRINT WILL ONLY BE USED AS A RECORD OR TO IDENTIFY OR INSPECT PARTS OR FOR OTHER INFORMATION PURPOSES, AND WILL NOT BE USED TO MANUFACTURE OR PROCURE THE MANUFACTURE OF THE PARTS SHOWN IN THIS PRINT BY ANY OTHER SOURCE THAN SELLERS CLEANING SYSTEMS AND CLOUD TANK COMPANY.

THIS DRAWING IS APPROVED FOR UNCONTROLLED DISTRIBUTION
AS A RESULT OF SELLERS CLEANING SYSTEMS CONSTANT PRODUCT IMPROVEMENT PROGRAM, PRODUCT CHANGES MAY OCCUR. AS SUCH, SELLERS CLEANING SYSTEMS RESERVES THE RIGHT TO CHANGE PRODUCT WITHOUT PRIOR WRITTEN NOTIFICATION

WWW.SELLERSCLEAN.COM

SHEET 3 OF 3

TITLE		CAGE NO	
2" TROLL BALL, BOLTED		96046	
DWG NO	REV		
CD-75-14-XB	D		



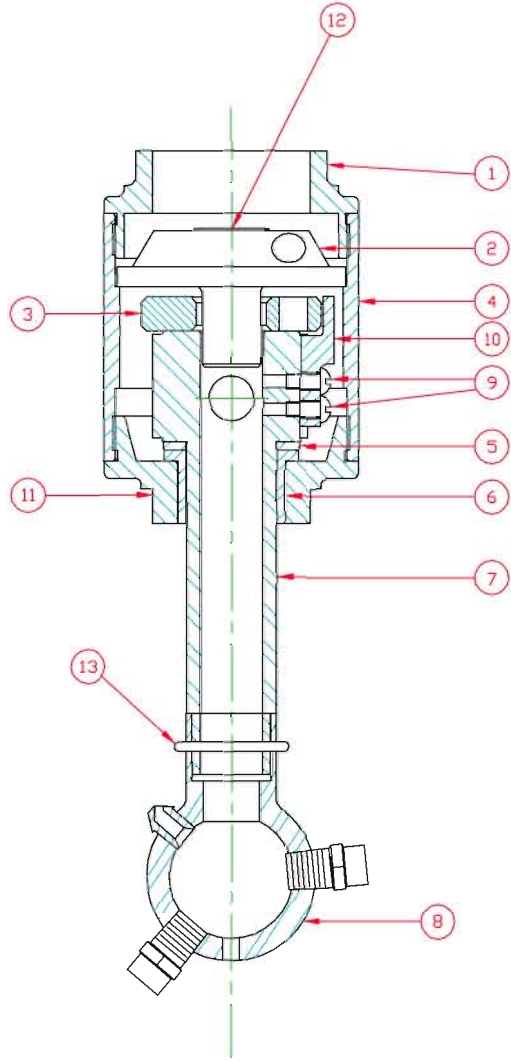

NOTES:

1) BALL INFORMATION

TROLL BALL	BALL PATTERN	BALL REF. NO.
75-16-C	'C'	75F-1615
75-16-D	'D'	75F-1620
75-16-G	'G'	75F-1622
75-16-H	'H'	75F-1625
75-16-B	'B'	75F-1638
75-16-E	'E'	75F-1639

- 2) USE THE FOLLOWING TORQUES FOR ASSEMBLY ITEM #1 WHILE HOLDING ITEM #3 TO 80 FT/LBS
 3) PLUG USED IN BY-PASS TO SPEED UP UNIT:

PLUG NO.	HOLE Ø
75-1624-C	.219
* 74-375	SOLID

- 4) APPLY A SMALL AMOUNT OF NEVER-SEEZ LUBRICANT (625-03561) TO ALL THREADS AT ASSEMBLY TO PREVENT GALLING.
 5) SPARE PARTS KIT NUMBER 75-16-SPK PARTS FOR THE KITS ARE IDENTIFIED WITH AN *

*	13	1	75-1415	PIN SPRING	316 SS
	12	1	SEE NOTE 3	PLUG	316 SS
	11	1	75-1604	CAP, BOTTOM	316 SS
*	10	1	75-1436	ARM, DRIVING	316 SS
*	9	2	2-61-1	SCREW RD HD #8-32 X .375	18-8 SS
	8	1	SEE NOTE #1	BALL	316 SS
*	7	1	75-1606	SHAFT, TROLL BALL	316 SS
*	6	1	75-1608	BUSHING	TEFLON
*	5	1	75-1609	WASHER	TEFLON
	4	1	75-1601	BODY	316 SS
*	3	1	75-1628	DISK, ROTOR	TEFLON
*	2	1	75-1605	MOTOR	316 SS
	1	1	75-1603	CAP, INLET	316 SS
	ITEM NO.	QTY REQD	PART OR IDENTIFYING NO.	NOMENCLATURE OR DESCRIPTION	MATERIAL/SPECIFICATION
PARTS LIST					

THIS PRINT IS AND CONTAINS PROPRIETARY INFORMATION OWNED EXCLUSIVELY BY SELLERS CLEANING SYSTEMS AND CLOUD TANK COMPANY. THIS RESTRICTION INCLUDES, BUT IS NOT LIMITED TO, THE CONDITION THAT THIS PRINT WILL ONLY BE USED AS A RECORD OR TO IDENTIFY OR INSPECT PARTS OR FOR OTHER INFORMATION PURPOSES, AND WILL NOT BE USED TO MANUFACTURE OR PROCURE THE MANUFACTURE OF THE PARTS SHOWN IN THIS PRINT BY ANY OTHER SOURCE THAN SELLERS CLEANING SYSTEMS AND CLOUD TANK COMPANY.

THIS DRAWING IS APPROVED FOR UNCONTROLLED DISTRIBUTION
 AS A RESULT OF SELLERS CLEANING SYSTEMS CONSTANT PRODUCT IMPROVEMENT PROGRAM, PRODUCT CHANGES MAY OCCUR. AS SUCH, SELLERS CLEANING SYSTEMS RESERVES THE RIGHT TO CHANGE PRODUCT WITHOUT PRIOR WRITTEN NOTIFICATION
 WWW.SELLERSCLEAN.COM SHEET 3 OF 3

TITLE 3" TROLL BALL, PIN			CAGE NO 96046
DWG NO CD75-16-X	REV B	CLOUD SELLERS	

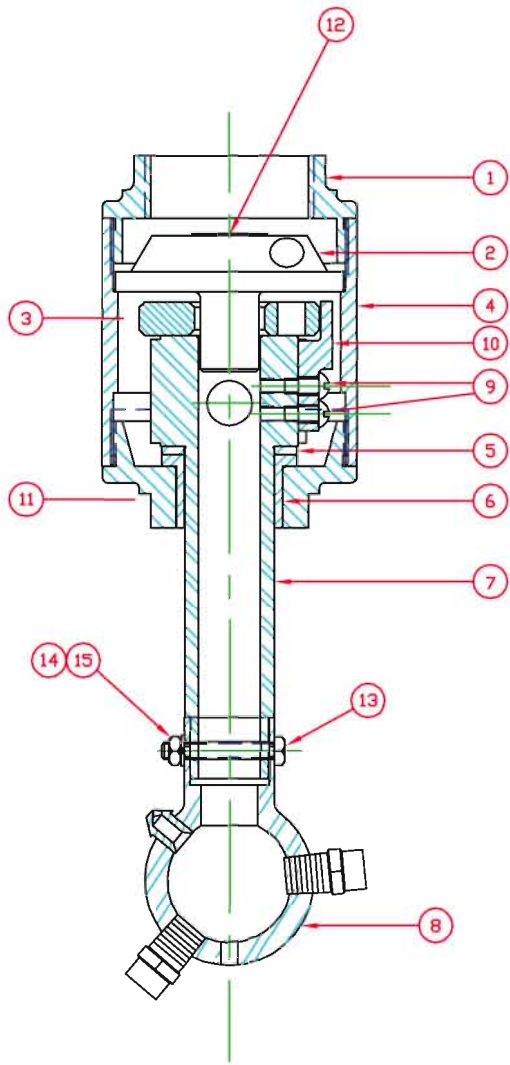

NOTES:

1) BALL INFORMATION

TROLL BALL	BALL PATTERN	BALL REF. NO.
75-16-CB	'C'	75F-1615B
75-16-DB	'D'	75F-1620B
75-16-GB	'G'	75F-1622B
75-16-HB	'H'	75F-1625B
75-16-BB	'B'	75F-1638B
75-16-EB	'E'	75F-1639B

2) USE THE FOLLOWING TORQUES FOR ASSEMBLY ITEM #1 WHILE HOLDING ITEM #3 TO 80 FT/LBS

**3) PLUG USED IN BY-PASS TO SPEED UP UNIT:
* = SUPPLIED WITH UNIT**

PLUG NO.	HOLE #
75-1624-C	219
74-375	SOLID

4) APPLY A SMALL AMOUNT OF NEVER-SEEZ LUBRICANT (625-03561) TO ALL THREADS AT ASSEMBLY TO PREVENT GALLING.

5) SPARE PARTS KIT NUMBER 75-16B-SPK PARTS FOR THE KITS ARE IDENTIFIED WITH AN *

ITEM NO.	QTY REQD	PART OR IDENTIFYING NO.	NOMENCLATURE OR DESCRIPTION	MATERIAL/SPECIFICATION	
*	15	1	108331	NUT, HEX, #10-32 THD.	SS
*	14	1	20-12-1	LOCKWASHER, SPLIT #10 THD.	18-8 SS
*	13	1	1-403-1	SCREW, HX. HD. #10-32 X 1.25	18-8 SS
	12	1	SEE NOTE #3	PLUG	316 SS
	11	1	75-1604	CAP, BOTTOM	316 SS
*	10	1	75-1436	ARM, DRIVING	316 SS
*	9	2	2-61-1	SCREW, RD. HD. #8-32 X .375	18-8 SS
*	8	1	SEE NOTE #1	BALL	316 SS
*	7	1	75-1606B	SHAFT, TROLL BALL	316 SS
*	6	1	75-1608	BUSHING	TEFLON
*	5	1	75-1609	WASHER	TEFLON
	4	1	75-1601	BODY	316 SS
*	3	1	75-1628	DISK, ROTOR	TEFLON
*	2	1	75-1605	MOTOR	316 SS
	1	1	75-1603	CAP, INLET	316 SS

THIS PRINT IS AND CONTAINS PROPRIETARY INFORMATION OWNED EXCLUSIVELY BY SELLERS CLEANING SYSTEMS AND CLOUD TANK COMPANY. THIS RESTRICTION INCLUDES, BUT IS NOT LIMITED TO, THE CONDITION THAT THIS PRINT WILL ONLY BE USED AS A RECORD OR TO IDENTIFY OR INSPECT PARTS OR FOR OTHER INFORMATION PURPOSES, AND WILL NOT BE USED TO MANUFACTURE OR PROCURE THE MANUFACTURE OF THE PARTS SHOWN IN THIS PRINT BY ANY OTHER SOURCE THAN SELLERS CLEANING SYSTEMS AND CLOUD TANK COMPANY.

THIS DRAWING IS APPROVED FOR UNCONTROLLED DISTRIBUTION
AS A RESULT OF SELLERS CLEANING SYSTEMS CONSTANT PRODUCT IMPROVEMENT PROGRAM, PRODUCT CHANGES MAY OCCUR. AS SUCH, SELLERS CLEANING SYSTEMS RESERVES THE RIGHT TO CHANGE PRODUCT WITHOUT PRIOR WRITTEN NOTIFICATION
WWW.SELLERSCLEAN.COM SHEET 3 OF 3

TITLE		3" TROLL BALL, BOLTED		CAGE NO	96046
DWG NO	CD75-16-XB	REV	D		